

# OmniGraffle PRO

Manual

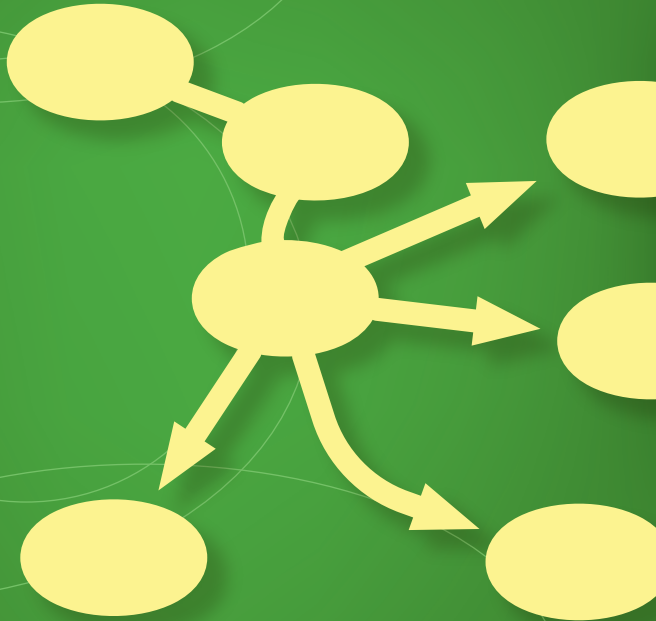

# OmniGraffle PRO Manual

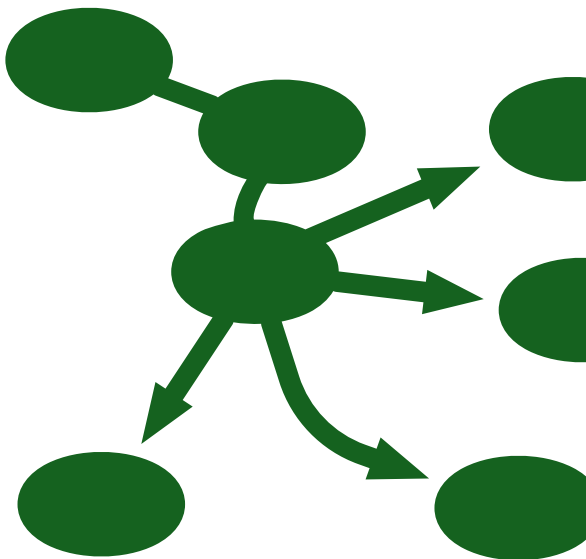

Version 4.0



Copyright© 2000-2006 The Omni Group. All rights reserved. OmniGraffle, the OmniGraffle icon/logo, and the Omni logo are trademarks of The Omni Group. Apple, the Apple logo, Mac, Macintosh, and the Mac logo are trademarks of Apple Computer, Inc., registered in the U.S.A. and other countries. Other names and marks mention herein may be trademarks of their respective companies.



# Contents

---

<b>Chapter 1</b>	<b>5</b>	<b>Hello!</b>
	5	Welcome to OmniGraffle
	5	Welcome to This Manual
	6	What's New in OmniGraffle 4
	9	Installation
<b>Chapter 2</b>	<b>13</b>	<b>Let's Try It</b>
	13	Meet the Canvas
	15	Mini-Tutorial: Essential Tools
	19	Tutorial: Much Ado About Graffling
<b>Chapter 3</b>	<b>35</b>	<b>An In-Depth Look</b>
	35	Inspectors
	43	Toolbar
	44	Tool Palette
	50	Utility Drawer
	52	Stencils
	53	Preferences
	55	Save, Print, Import, Export
<b>Chapter 4</b>	<b>59</b>	<b>Help</b>
	59	Onscreen Help
	59	Walkthroughs
	60	Further Help





---

## Welcome to OmniGraffle

Everyone needs to communicate visually, because everyone has ideas that can't be expressed by words alone. OmniGraffle exists to help you convey your ideas visually, make sense of them, and present them to others as clearly as possible.

Any graphics program can make a beautiful picture to express *glory* or *Weltschmerz*, but OmniGraffle can make a beautiful picture to express this database contains forty-seven tables or let's put the cactus over there in the corner. The next time you have a complicated concept you need to sort out, or someone wants you to "show me don't tell me", you'll be able to whip up an organized, attractive diagram in no time.

Of course, you can also use OmniGraffle to create everyday documents like photo albums, yard sale flyers, CD covers, garden layouts, newsletters, and almost anything else you can think of. Draw pretty pictures, lay out text, connect shapes together, turn outlines into graphics, drag in images... the list goes on and on.

## Welcome to This Manual

OmniGraffle can handle a huge set of different tasks, and we are constantly surprised by the new uses people find for it. This manual is here to get you acquainted with the software so that you can discover how you would like to use it.

You can refer back to this manual for general guidance and ideas. If you have a question about a specific detail, try the searchable onscreen help files in OmniGraffle's **Help** menu.

## What's New in OmniGraffle 4

This is the fourth major release of OmniGraffle, and we'd like to take a few moments to tell our upgrading customers what is new since version 3. If you've never used OmniGraffle, congratulations — **everything** is new!

We will cover each of these features in more depth in later chapters, so whether you're a new user or not, you're welcome to skip along to the next chapter (on page 4).

### Interface Improvements

The **utility drawer** makes a stronger connection between canvases, layers, and the documents they belong to. It also facilitates drag-and-drop actions between documents.

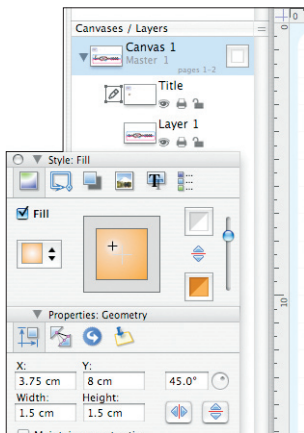

OmniGraffle Pro can base multiple canvases on a **master canvas**, giving them a common foundation.

Eighteen **inspectors** have been consolidated into three inspector windows, with even more functionality. Each inspector window has tab-like buttons for switching between inspectors.

## Brainstorming

Use the startlingly useful **outline view**, in the utility drawer, to rapidly enter data from the keyboard; watch as your outline is transformed into a diagram.

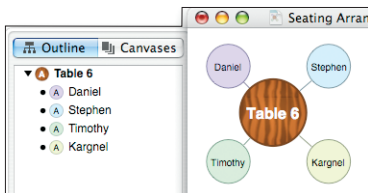

**Diagram styles** define the appearance of a diagram: use them to style a diagram as you enter it in the outline view, or apply one to an existing diagram or OmniOutliner file for instant beauty.

New keyboard and mouse shortcuts (like selecting a shape and then Command-clicking the canvas) ease the creation of epic quantities of data.

In OmniGraffle Pro, use **notes** to attach extra information to objects and maintain consistency with OmniOutliner documents.

## Drawing and Drafting Improvements

In OmniGraffle Pro you can quickly create **tables** and easily populate them with data.

The new **pen tool** replaces the polygon tool; it supports Bezier curves, which we're pretty sure is French for "bendy lines".

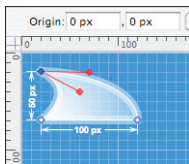

The Edit menu of OmniGraffle Pro now contains commands for mathematically **combining multiple shapes** into one object.

When you're drawing something to scale, OmniGraffle Pro's new **ruler** really comes in handy. Set up a ruler scale such as "1 in = 2 ft" or "100 px = 1 km" and OmniGraffle takes care of the rest.

The **style brush** can now pick up specific style attributes.

The new **magnet tool** can edit an object's magnets right on the canvas.

## Import & Export Improvements

OmniGraffle now supports LinkBack, a lovely way to embed data from one application in a document of a different application.

Two new export formats are available: **SVG** (for OmniGraffle Pro) and **vector PICT**.

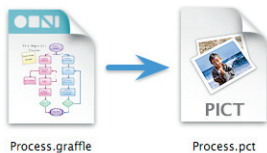

Nearly all existing import and export options have been greatly refined and improved.

# Installation

## 1. Mount the Disk

If you have a physical OmniGraffle disk that came in a box, put the disk in your Mac's CD or DVD drive. If you have downloaded an OmniGraffle disk image, double-click it (the **.dmg** file) to mount it.



## 2. Copy the Application

Drag the OmniGraffle application icon from the disk into your Applications folder. This can be the Applications folder in the root level of your hard drive (so that all users on your Mac can access it) or the one in your home folder (so that only you can access it).

If you already have a copy of OmniGraffle installed, you're asked whether you want to replace it. If you don't mind losing your old copy, go ahead and replace it; otherwise try moving the old copy somewhere else or renaming it.

When the copy is done, you don't need the disk anymore; eject the CD or eject and delete the disk image.

## 3. Run OmniGraffle

Double-click OmniGraffle's icon to run it; if this is the first time you've used it, and you don't have any licenses installed yet, you'll see the Licenses dialog. If you don't see it, and you want to install a license, select **Licenses** from the **OmniGraffle** menu.

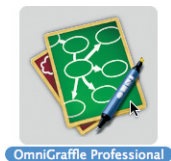

## 4. Add a License

Click the **Add License** button. In the dialog that appears, type your name into the Owner field; if you bought a license online, the owner name must be *exactly* the same as the owner name in your e-mail receipt; even the capitalization must be the same.

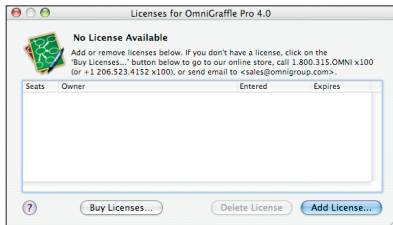

Type your license key into the **License Key** field. If you bought OmniGraffle in a physical box, your license key should be printed on a sticker attached to the CD sleeve. If you bought OmniGraffle online, you can copy and paste the license key from the e-mail receipt.

## Choose from the three different types of licenses:

- A **Computer** license can be used by any user on that one computer. This is the most basic type of license.
- A **Personal** license can only be used when you are logged in as the user who installed it. You can, however, install and use it on any number of different computers as long as only one copy of the application is running at one time.
- A **Network** license is for environments with many users (such as companies and schools) to allow a certain number of users on the network to use the software at once.

Once your license key is accepted, click the **Save** button and you're set!

**OG4 TIP****Registering OmniGraffle**

If you bought OmniGraffle in a physical box, it helps to register your new license at our web site. This lets us connect your license key and your name so that we can support you better: you can upgrade to new versions of the software at discounted prices, and we can retrieve your license key for you later if you lose it. We'll never, ever, ever give your personal information to anyone else, or do anything inappropriate with it (ever).

<http://www.omnigroup.com/applications/registration/>





## Meet the Canvas

### Tool palette

The indispensable **tool palette** can live in the toolbar, or it can float in a separate window of its own.

### Toolbar

The customizable **toolbar** is a standard element of many Mac OS X applications. Fill it with your favorite controls to work more quickly.

### Ruler

The innocuous **ruler** is actually a powerful alignment, spacing, and scaling tool. Work with the units that make the most sense, from pixels to miles.

### Utility Drawer

The **utility drawer** contains the handy new **outline view**. It also has a list of **layers** on the canvas, and in OmniGraffle Pro, a list of **canvases** in the document.

### Canvas

The **canvas** is your *tabula rasa*, where your creation takes form. Create objects, connect them with lines, and move them around as you see fit.

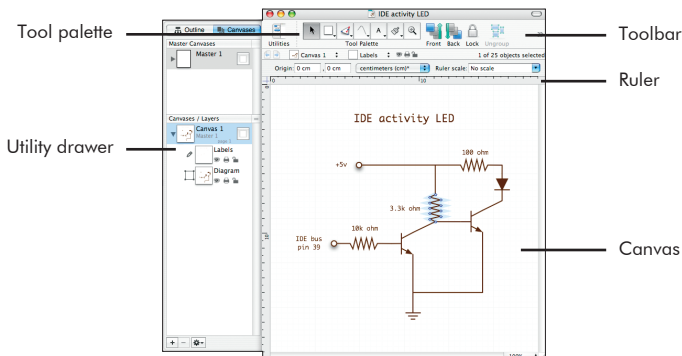

## Meet the Canvas

### Inspectors

Fifteen delectable **inspectors** give you complete control over the current selection, from text, to objects, to a whole canvas. Summon and dismiss each one as you see fit.

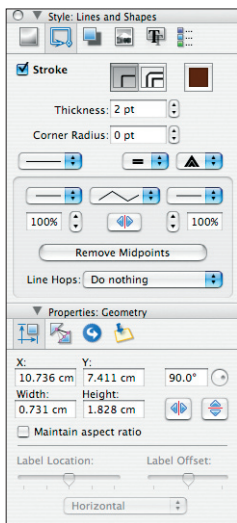

### Stencils

These crafty **stencils** provide quick access to objects you use frequently. You can even make your own and share them with other creative geniuses.

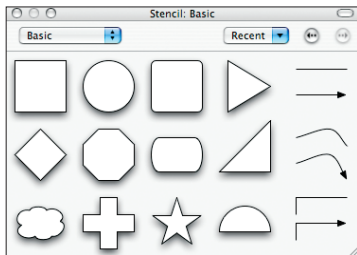

## Mini-Tutorial: Essential Tools

### 1. Your Quest

OmniGraffle starts you out with a blank canvas. Your quest is to put objects on that canvas and connect them together.

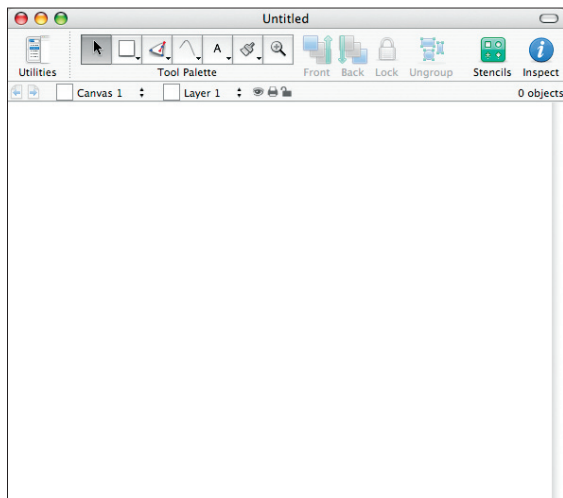

### 2. Shapes

If you don't have a blank document open yet, select **New** from OmniGraffle's **File** menu.

Let's start simply, by creating a single shape. Click the Shape tool once; it's the second button in your tool palette, and probably has a white square on it (unless somebody changed it on you).

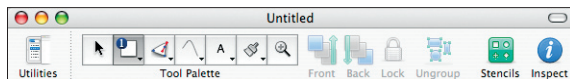

With the Shape tool selected, click and drag across the canvas to create a reasonably-sized shape object.

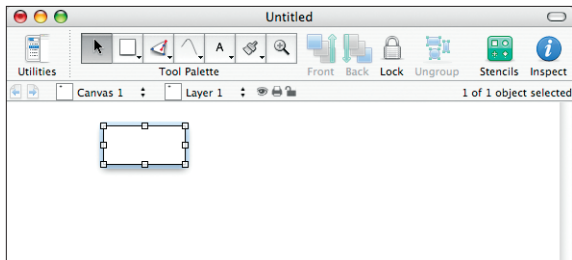

That was fun. Let's create another shape in a different way: from the **Stencils** menu, choose **Basic**. This summons the basic stencil, which contains a whole lot of commonly-used objects. From the stencil, drag a shape that appeals to you and drop it on the canvas near your first shape.

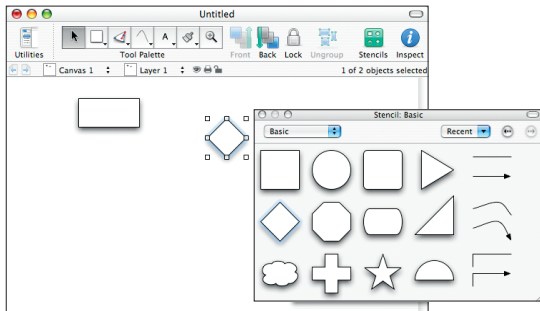

### 3. Text

Objects have a lot more meaning when they're labeled. Click the Text tool once; it looks like a letter 'A'.

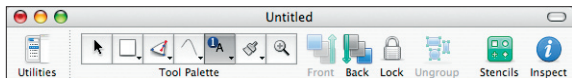

With the Text tool, click your first shape object. You get an insertion point for entering text. Type something to identify the object, like “1” or “rectangle” or “asdf”.

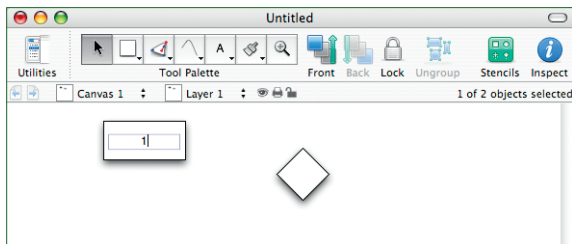

Click the Text tool once more, then click the other object. Name it something else, like “2” or “not rectangle” or “Douglas”.

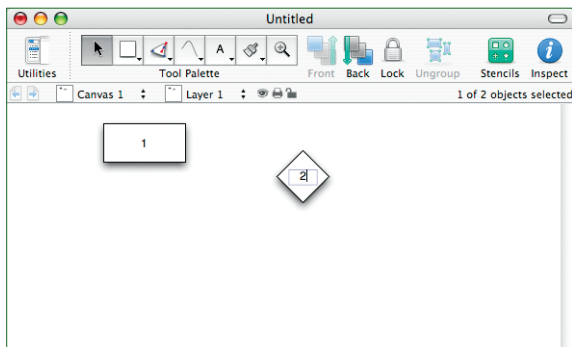

## 4. Lines

Things are about to get interesting. Click the Line tool once; it should be the fourth tool in your palette, and it looks like... a line.

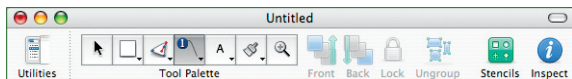

With the Line tool selected, maneuver the crosshair onto your first shape, see the shape pulsate to let you know you're about to connect to it, and click. Then put the crosshair on your second shape, see it also make with the pulsation, and click again.

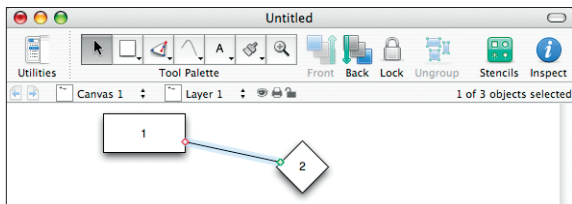

Now you have two shapes connected by a line. This is the soul of OmniGraffle: connected objects stay connected. The line stretches and moves to keep the shapes connected no matter how they are restyled or moved around.

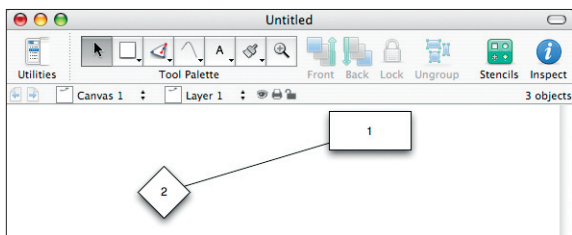

You can use lines to represent any kind of relationship between objects: related ideas in a brainstorm, ancestry in a family tree, or order in a sequence, just to name a few. Remember that, when creating lines, the order in which you click objects matters; the first object you click is the “source” of the line, and the second object you click is the “destination”. This determines at which end of the line the arrowheads appear and affects objects’ hierarchy when you use the automatic layout or the outline view.

## 5. You’ve got it

Every object in OmniGraffle is a shape or a line; any object (even a line) can be connected to any other object by a line.

With this knowledge, you can diagram almost anything. The rest is just details.

# Tutorial: Much Ado About Graffling

## 1. Welcome

OmniGraffle excels at clarifying complex relationships, and nothing says “complex relationships” like a Shakespeare romantic comedy. Let’s try to make some sense of *Much Ado About Nothing*, and learn a bit about OmniGraffle in the process. Of course, this play is just a handy example; if there’s another story you’re more familiar with, you can go ahead and use it instead. *The Tale of Genji*, *Steppenwolf*, *The Fifth Element*... Whatever works best for you.

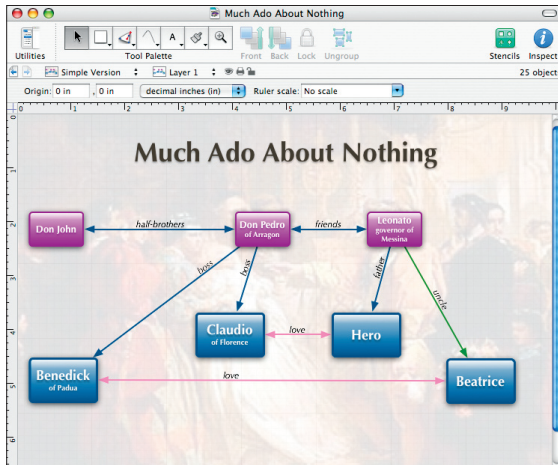

When you’re finished, you’ll have a diagram that looks something like this one. Yes, it’s very nice, thank you. You can make one too; it’s easy.

Create a fresh document by selecting **New** from the **File** menu and we’ll get started.

## 2. Creating objects with the outline view

You’ve already learned in the mini-tutorial how to create shapes and connect them. But there’s another clever way to enter data: the outline view. If you’ve ever used an outliner (say, OmniOutliner, a fine product indeed), this should come naturally to you. If not, you’ll probably pick it up easily anyway.

Continued on next page ➤



First, if the utility drawer isn't open, select **Show Utility Drawer** from the **View** menu (or click the **Utilities** icon in the toolbar). The **Outline** tab at the top of the drawer is selected by default.

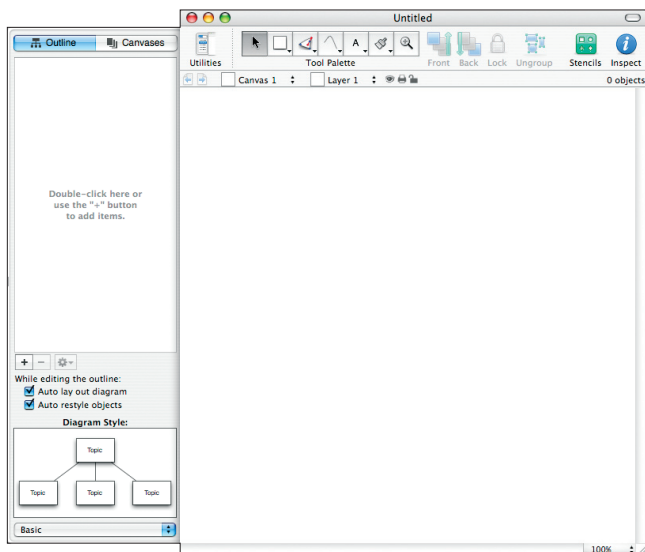

The big blank area in the drawer is your outline, which, just like the canvas, starts out empty. Don't worry about the controls at the bottom of the drawer just yet. Double-click the outline area to create your first item. An item called "Topic" appears in the outline, and simultaneously a shape labeled "Topic" appears on the canvas.

The item's text is already highlighted, so you can just start typing to rename it. This item represents our first character, so type "Don John".

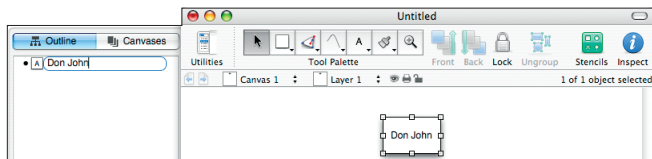

Press Return to finish with this item and move on to the next one. A new item appears below the first one in the outline, and a new shape appears on the canvas. Name this one “Don Pedro”.

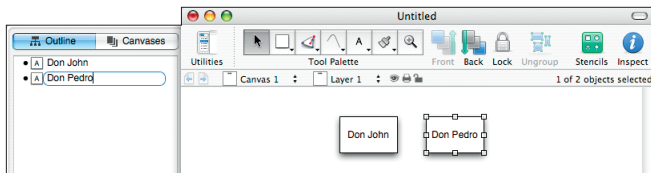

Press Return once more to create a third item, and name it “Leonato”. Now you have three items in your outline and three shapes on your canvas.

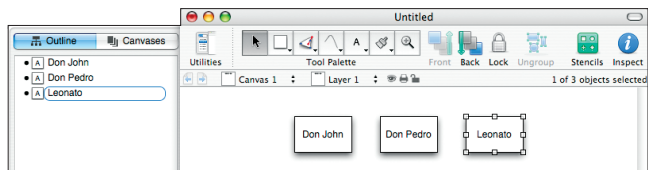

### 3. Outline hierarchy

It’s nice that you can create shapes quickly from the keyboard like this, but the real magic is in adding depth to the outline. All of the characters you’ve created so far exist on the same level, but now let’s add some more characters one level below them.

The next two characters are soldiers who fought under Don Pedro’s command, so we’ll add them below him in the diagram. Click the Don Pedro item in the outline to select it, then press Return to create a new item below it. Name the new item “Benedick”.

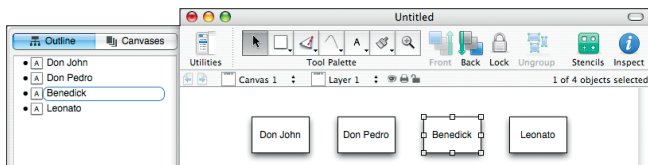

Now press the Tab key; Benedick in the outline becomes indented, and the corresponding shape on the canvas gets a connection line from Don Pedro. With Benedick still selected, press Return to create another item at the same level and name it “Claudio”. Now you have two characters that “belong” to Don Pedro.

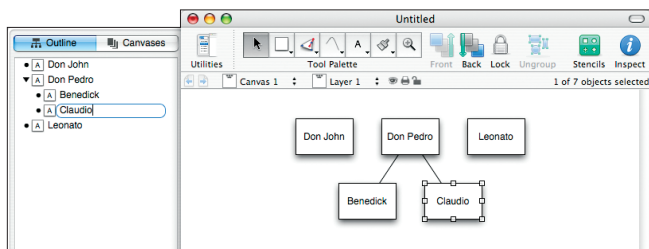

Now use the same technique to add Beatrice and Hero underneath Leonardo; they’re his niece and his daughter. In the diagram, you’ll see that they exist on the same level as Benedick and Claudio, but are connected to Leonardo instead of Don Pedro.

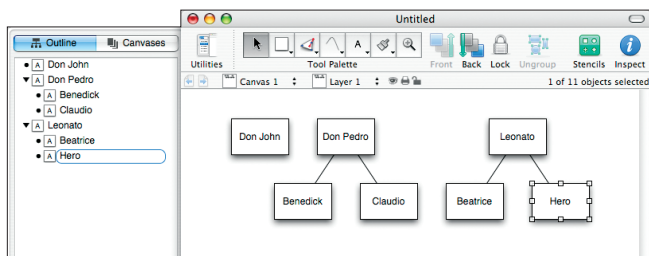

#### 4. Line Labels

To clarify the relationships we have so far, let’s use the Text tool to add labels to the connection lines.

Click the Text tool twice; it’s the one with a letter ‘A’ on it. If you click a tool twice, you can use it several times in a row. If you only click once, it reverts to the Selection tool after one use.

Position the pointer over the line between Don Pedro and Claudio. The line becomes highlighted; click it. Type “boss” into the label’s text to show that Claudio works for Don Pedro.

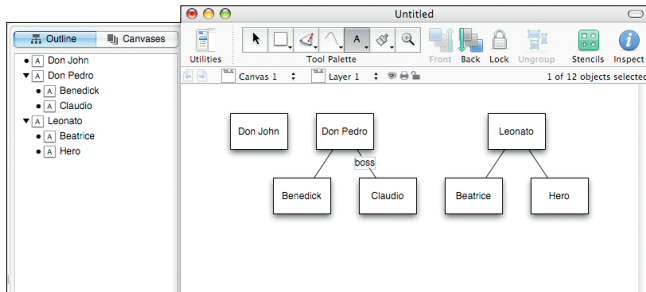

Add labels to the three remaining lines in the same way, indicating that Don Pedro is also Benedick’s “boss”, and that Leonato is Hero’s “father” and Beatrice’s “uncle”.

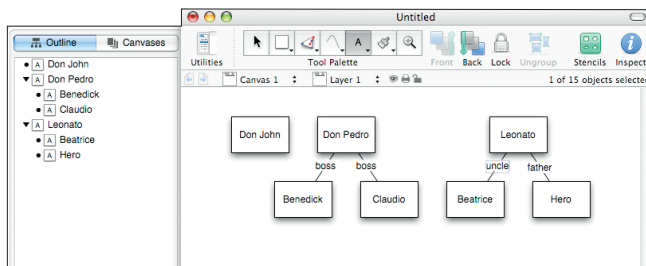

## 5. Making more connections

You’ve already got a fine diagram, but sometimes you want to diagram relationships that are not strictly tree-like. Let’s manually add some more connections. If, while you do this, any connection lines look awkward, feel free to use the Selection tool to drag shapes into more comfortable locations. You can’t ruin anything by just moving shapes around.

Let's make the Line tool match the lines already on the canvas. Click and hold on the Line tool button in the tool palette, and a menu appears. Under **Canvas Styles**, select the **Straight, Stroke: Black** entry. Now the lines you make with the Line tool will look the same as the lines that were created automatically by the outline view.

Add the connection lines just like you did in the first tutorial: with the Line tool selected, click one shape then the other. Make connections and label them to signify the following relationships: Don John and Don Pedro are half-brothers; Don Pedro and Leonato are friends; Hero and Claudio are in love; Benedick and Beatrice are (eventually) in love.

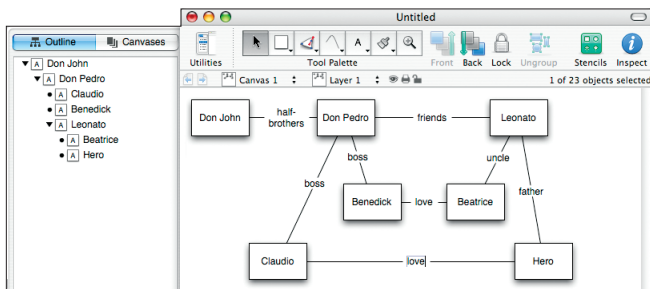

Now that the diagram is more complicated than a simple outline, you won't be needing the outline view any more. Choose **Hide Utility Drawer** from the **View** menu or click its icon in the toolbar.

## 6. Styling objects

Look at your work so far—no literary minutia can escape your organizational prowess! Okay, so, the diagram makes sense, but it's not particularly attractive. Let's pretty up those objects with some style attributes. Start by selecting Don John.

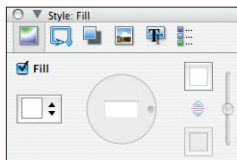

We're going to meet the inspectors: convenient little windows full of controls that you can use to modify any object on the canvas, or the canvas itself. There are six Style inspectors, each one of which controls a certain element of the selected objects' appearance. The first inspector we'll use is the Fill inspector; if you don't see it on your screen, select **Fill** from the **Style** section of the Inspectors menu.

Right now the selected object has a plain white fill color. Click the color well in the inspector's upper-right corner and then use the Colors panel that appears to choose a new fill color. If you like, you can even choose a blend style from the menu at the left of the inspector, then choose a different color for each well that appears.

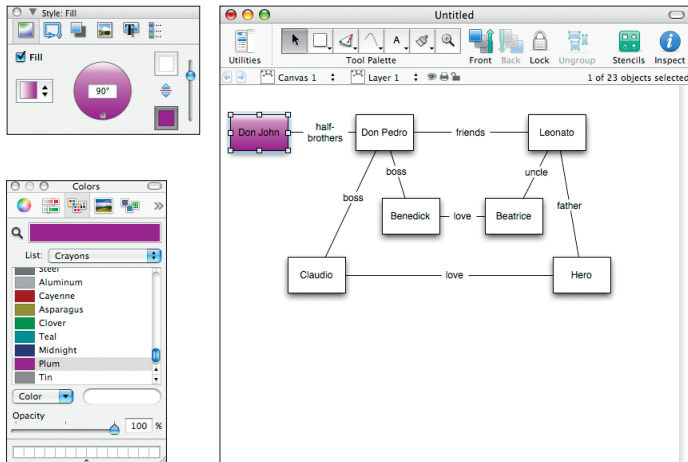

Next let's use the Lines and Shapes inspector to change the line drawn around the outside of the shape. There are six icons across the top of the Style inspectors window; click the second one to switch to the Lines and Shapes inspector. From there, try setting the stroke thickness to **2pt**, and the corner radius to **5pt**. This makes for a nice, heavy, rounded stroke around the shape. Choose a nice stroke color just like you did for the fill color.

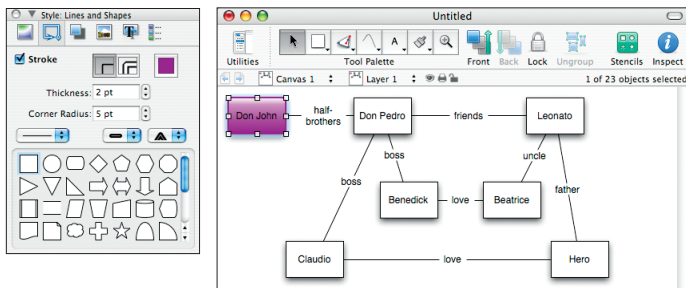

Switch to the Text inspector and click the Font button (the one with a big letter 'A'); this summons the standard Mac OS X font panel. Choose a nice font, then click the color well next to the Font button and choose a nice color. Now you should have one quite charming shape object.

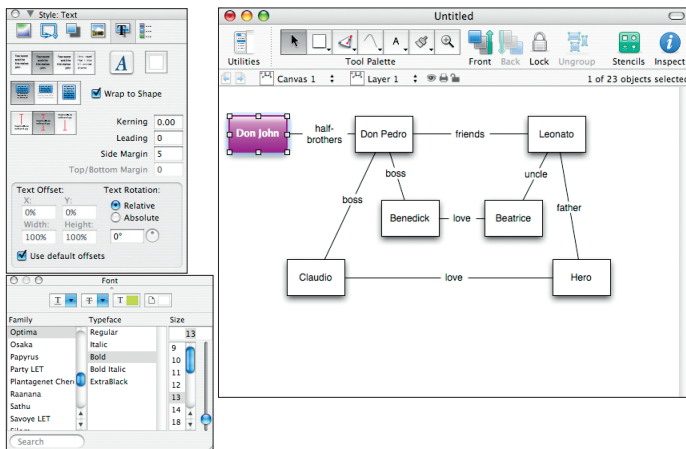

## 7. Proliferating styles

The next step is to apply the same styles to your other shapes without repeating every step for each one.

Switch to the Summary inspector; it contains a list of all style attributes for the currently selected object. Each style attribute is represented by a tiny square “style chit” and a text description. With the Don John shape still selected, drag its “All Styles” chit from the Summary inspector and drop it onto the Don Pedro shape in the diagram.

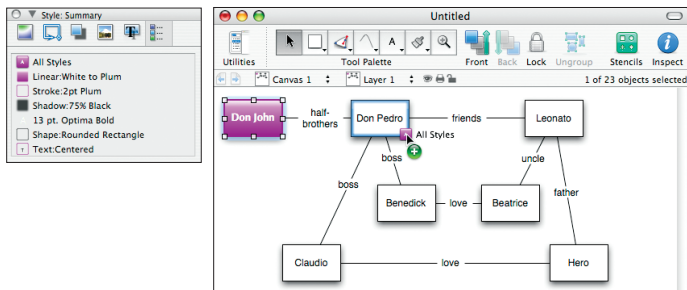

Whoa! That’s pretty easy. Do the same thing to Leonato so that all of the elder generation characters have a consistent appearance.

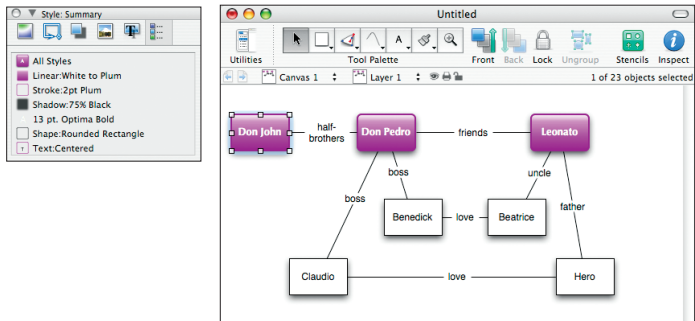



## 8. More selecting and styling

Let's style the remaining objects. A quick way to select lots of shapes at once is with the Selection inspector, which is part of the Canvas inspectors window. If you don't see it on your screen, select it from the **Inspectors** menu.

The Selection inspector lists all of the different kinds of objects on the canvas, based on their styles. The Selection inspector shows that you have one out of three colored rectangles selected. There should be an item representing the four plain white rectangles with black strokes; click it to select all such objects at once, and it changes to show that you have selected four of four such objects.

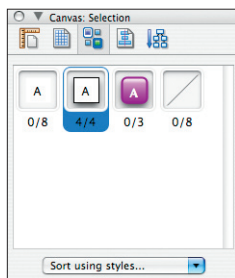
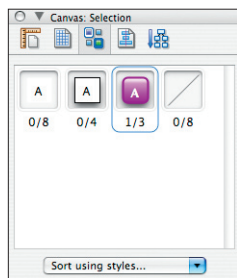

You can use the Properties inspectors to change aspects of an object that are not strictly related to its visual style. We'll use the Geometry inspector to change the size of the four selected objects. If the Geometry inspector is not on your screen, select it from the **Inspectors** menu. In the width and height fields, enter some new values to make these shapes somewhat larger than the others.

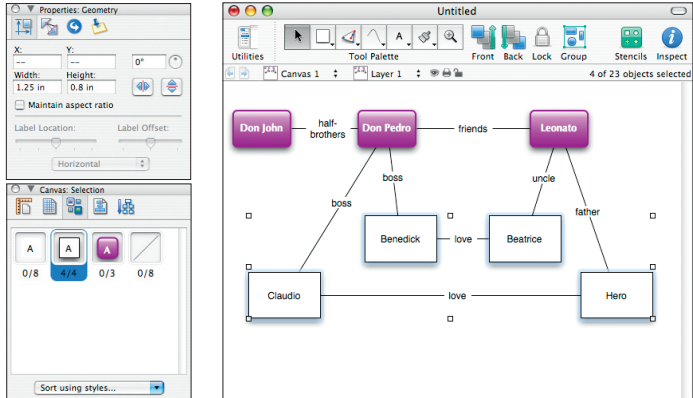

Use the Style inspectors to simultaneously style all four shapes in a way that differentiates them from the others. Here we've chosen a different color, a slightly thicker stroke, and a larger font.

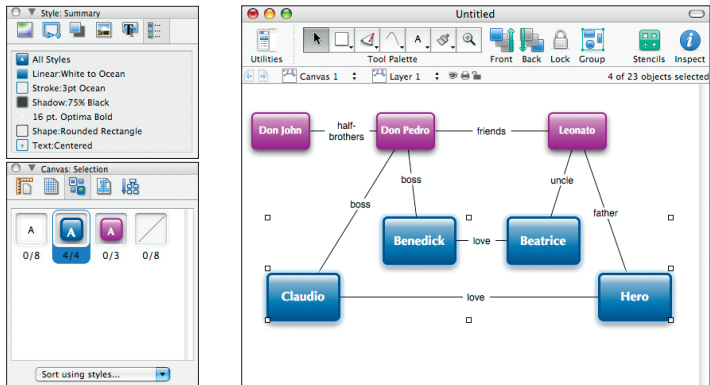

Continued on next page ➤

## 9. Layers

Layers contain separate sets of objects on one canvas; the layers of a canvas appear one on top of another according to their order. We'll put our background image on a new layer to keep it separate from the character diagram.

Show the utility drawer again, and this time click the tab labeled **Canvases** (if you're using OmniGraffle Pro) or **Layers** (if you're using OmniGraffle Standard). In OmniGraffle Pro, click the disclosure triangle to the left of "Canvas 1" to see the layers. In OmniGraffle Standard, the layers are already visible.

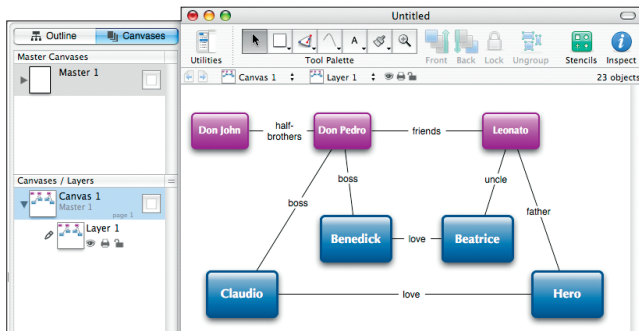

You only have one layer right now, so let's add another one. Click "Layer 1" to select it, then click the plus button at the bottom of the drawer. A new layer is born. You can name it if you like; something like "Background" should suffice.

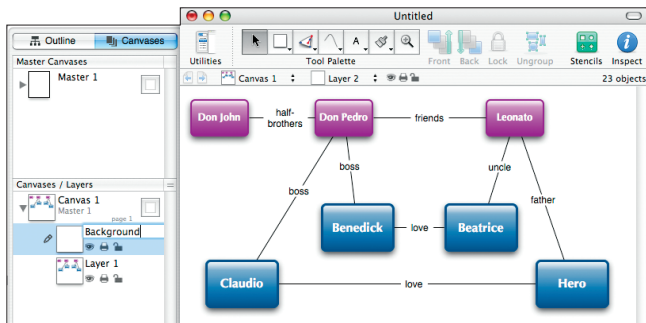

The order of layers is important; stuff on top layers appears in front of stuff on bottom layers. We want the background to appear behind our relationships diagram, so drag the new layer and drop it below the other one in the list.

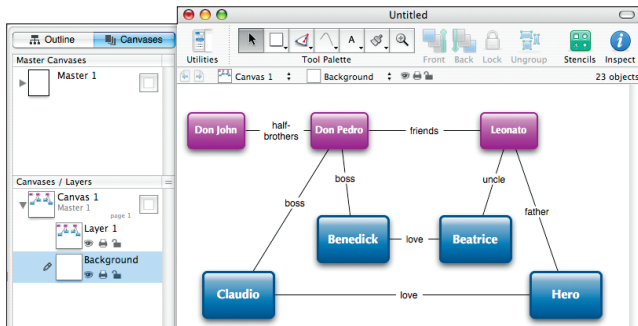

Let's concentrate on the background layer. The layer you're working with right now has a pencil icon to the left of its preview in the drawer. If the background layer doesn't have the pencil icon, click just to the left of the layer preview to put it there.

Find a nice background image on one of your disks. Drag the image file from the Finder and drop it on the canvas area. A new shape object containing the image is created on the background layer.

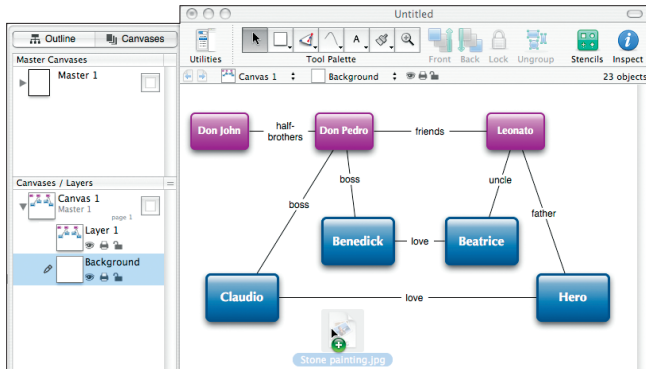

Drag the selection handles on the corners of the shape to stretch it to a nice big size; hold Shift as you drag to keep the image from getting distorted. Then use the Image inspector to set the image's opacity to about **10%**.

## 10. Completion

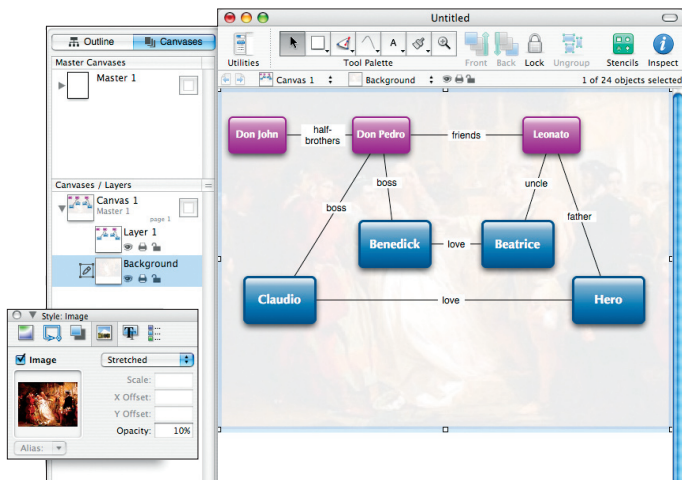

Now you have an attractive, informative diagram. You know how to use the outline view to create objects, how to label and connect them, and how to add styles. You know how to propagate styles around to many objects. You know how to use multiple layers. At this point, you're pretty much unstoppable!

### OG4 PRO TIP

#### Presentation mode

When you're ready to show your document to a room full of people, use OmniGraffle Pro's presentation mode. Just select Presentation from the View menu, and your diagram grows to fill the entire screen. Click or use the arrow keys to move between canvases, point at an object to highlight it, and click an object to perform its assigned action. If you have two displays, you can even show the presentation on one while editing the canvas normally on the other. Classy, yes?

## 11. Overachievers' Corner

If you're ambitious, try getting your diagram to look like this.

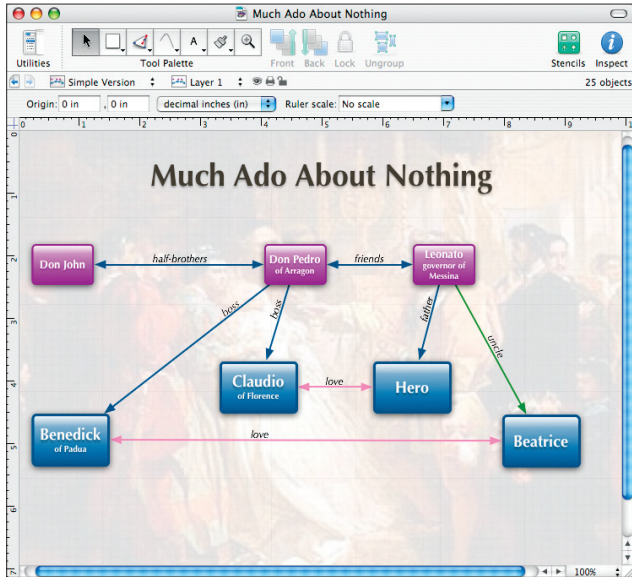

It might be helpful to lock the background layer by clicking its little padlock icon in the utility drawer; this prevents you from accidentally selecting or changing the background image.

The title can be created with the Text tool, the style of the connection lines can be changed from the Lines and Shapes inspector, and the positioning of the line labels can be changed with the Geometry inspector.



## Inspectors

The inspectors are little windows you use to edit the objects and canvases in your diagrams. You can drag them around by their title bars like any other window, or open and hide the different panes in each inspector window by clicking the icons across the top of each one.

If you need a hint about the purpose of a particular control on an inspector, just put the pointer over it for a moment. Most controls show a help tag with a brief description of their purpose.

## Style inspectors

These inspectors control everything about the appearance of the objects that are currently selected on the canvas. Most changes you can make to an object's appearance are immediately visible, so if you're not sure how something works, just play with it a bit and watch how the selected object changes.

- **Style: Fill inspector**

This fills the selected shape with a color, a gradient, or nothing at all. If you choose a gradient, you'll see more color wells and controls for setting the gradient's direction and position.

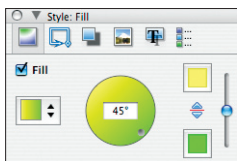



## • Style: Lines and Shapes inspector

Use the top half of the inspector to determine the style of a shape's outline or of a connection line.

If you have a shape selected, the bottom half of the inspector can be used to change that most important aspect of a shape object: its shape.

If you have a connection line selected, the bottom half of the inspector can be used to change the line endings, what kind of path the line follows, and how it behaves when crossing other lines.

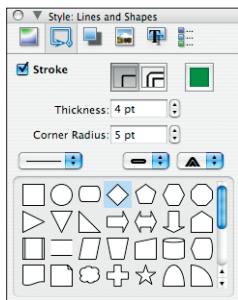

## • Style: Shadow inspector

Here you can choose whether the selected object should have a shadow, and whether the shadow should appear above or below overlapping objects on the same layer.

If you choose to give the selected object a shadow, you can set its color, position, and blurriness here.

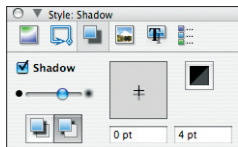

## • Style: Image inspector

You can place an image inside a shape. Select the Image checkbox to choose an image file, or just drag an image file into the well or onto the shape itself.

Once you have selected an image, you can use the other controls on the inspector to position and size it within the shape.

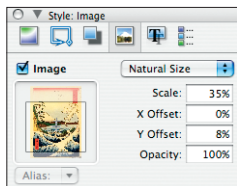

## • Style: Text inspector

Here are the controls for what an object's text looks like and where it is positioned relative to the object itself. You can set the text's horizontal and vertical alignment, how to handle overflowing text, and of course the font and color.

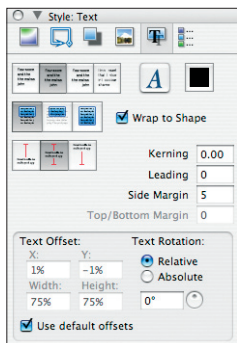

## • Style: Summary inspector

This is a list of all style attributes for the selected object. You can drag any or all of these styles onto an object on the canvas, or onto a class of objects in the Selection inspector, to apply them to that object.

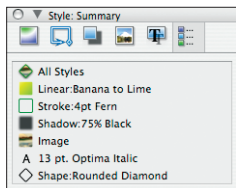

## Properties inspectors

These inspectors are concerned with everything about the currently selected objects apart from their visual style. Object positioning, size, and special behaviors are the kind of things you can control here.

## • Properties: Geometry inspector

Use this inspector's text fields to exert precise control over the position and size of the selected object. You can also change the orientation of an object with the rotation angle controls and flip buttons.

If the selected object is a line label, you can control the label's position and orientation in relation to its line.

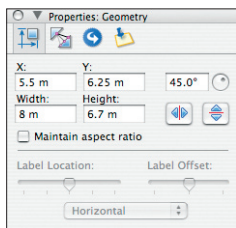

## • Properties: Connections inspector

One of the most important things OmniGraffle can do is use connection lines to logically associate objects. This inspector has controls for determining how the selected object connects to other objects.

There are a number of magnet presets to indicate where connection lines should connect to a shape. Different types of objects also have special controls here for determining how they connect to other types of objects, if at all.

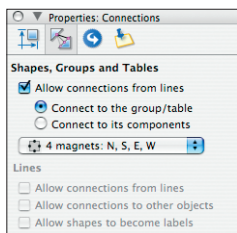

## OG4 TIP

### By the Way...

Inspectors are pretty smart. Try clicking in a number input field, then pressing the up or down arrow keys; the number increases or decreases step by step. You can enter simple arithmetic in these fields, like "2 \* 3 inches". Also, you can even enter values in whatever units you like. If OmniGraffle supports those units, they'll be automatically converted to the units set up in the ruler. (Sorry, no furlongs.)

## • Properties: Action inspector

You can set up an action to be taken when the selected object is clicked with the Browse tool. This is nice for creating interactive documents that make it easy for a user to navigate between canvases, open another file, or execute AppleScripts.

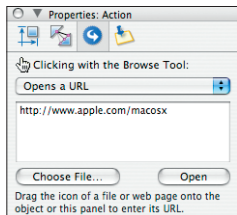

- **Properties: Note inspector**

Notes are a handy way to store arbitrary information about objects in a diagram. An object with a note displays the note in a tag when you rest the pointer over it for a moment.

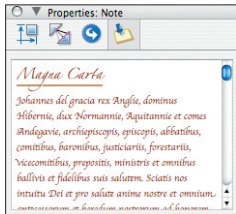

## Canvas inspectors

While the other inspectors control attributes of individual objects on a canvas, these ones control attributes of the canvas itself.

- **Canvas: Size inspector**

This inspector deals with the size, scale, and orientation of the current canvas, especially in relation to the printed page. You can select a canvas size based on how the canvas fits printed pages, or you can enter any arbitrary size. Likewise, you can scale the canvas to best fit the objects on it. You can also set up the orientation of pages (portrait or landscape), the zero-point of the rulers, and the page margins.

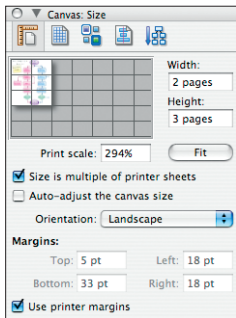

## • Canvas: Grid inspector

A grid can be helpful in getting objects laid out in just the right places. Use this inspector to control the grid's size and visibility, and to make objects snap into place on the grid as you move them.

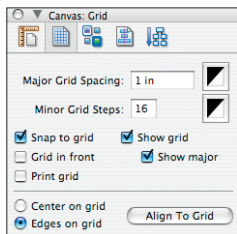

## • Canvas: Selection inspector

The Selection inspector is a handy little list of all the different types of objects on the canvas. Click an entry to select all objects that match it, instead of selecting the objects yourself one by one. Then you can change all of your purple ovals to key-lime octagons, or resize them all with the Geometry inspector, or give them all a shadow, or just delete them all, or whatever you need to do.

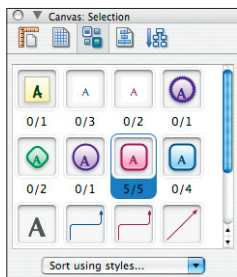

## • Canvas: Alignment inspector

Use this section to align objects in relation to each other or to the canvas. Click the vertical or horizontal align buttons to line up the objects just right. There are also buttons for distributing objects evenly along the vertical or horizontal axis, and for putting a certain distance between objects. The **Align to Canvas** checkbox allows for lining objects up according to the canvas edges.

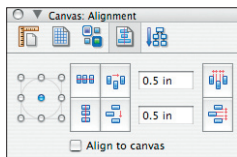

## • Canvas: Diagram Layout inspector

OmniGraffle can move objects around the canvas logically, based on their connection lines to other objects. Use this inspector to set when objects should be rearranged, or to do so on demand. You can also set the direction of the hierarchy, choose how child objects should be ordered, and force selected objects into certain hierarchy levels.

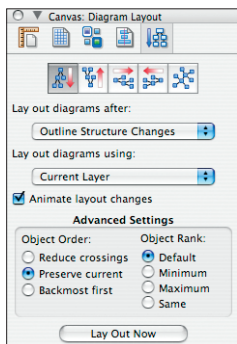

## Toolbar

Just like in other Mac OS X applications, you can customize the toolbar to contain whichever controls you like, or hide it completely. Use the **View ▶ Customize Toolbar** command to set up the toolbar however you like it, and use the white button on the right side of the title bar to show or hide the toolbar.

Most toolbar items just replicate menu items in a more convenient location. The notable exception is the tool palette, which is essential for creating diagrams. The next section for more information about the tool palette.

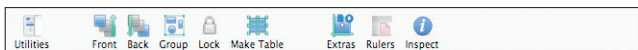
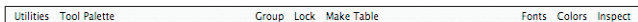
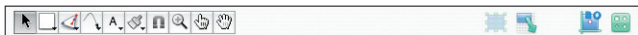
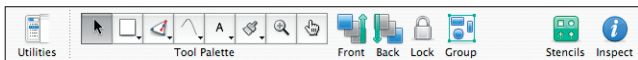



## Tool Palette

These are the tools you use to interact with the canvas. Each tool has a unique purpose, from creating new shapes to moving your view around. Click a tool once to activate it for one use; the number 1 appears on the tool to remind you of this. Click a tool twice to keep it activated until you click a different tool.

The Shape, Pen, Line, and Text tools have style menus that you can use to change the style of the objects that the tool creates. Click the tiny downward triangle on the tool, then select a style from the list. You can also choose **Inspect Style** and then use the Style inspectors to edit the tool as if it were an object on the canvas.

## Selection

The Selection tool is the most basic tool; click an object to select it, or drag an object to move it. Drag a line's points to reposition the line.

Drag a box around several objects to select them all at once, or hold Command as you click to add more objects to the current selection.

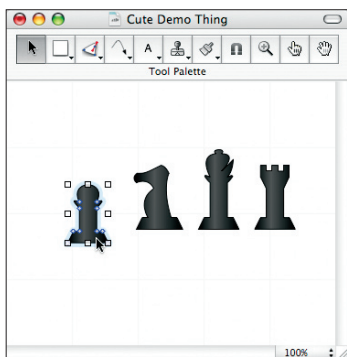

## Shape

Click and drag somewhere on the canvas to create a shape.

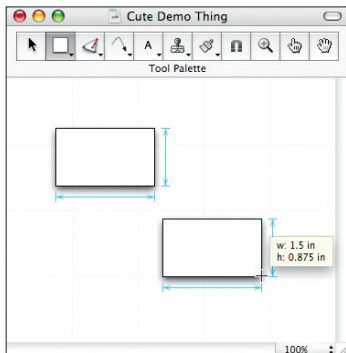

## Pen

Use the Pen tool to create shapes to your own liking. Click somewhere on the canvas to start drawing a shape, then keep clicking wherever you like to add more points. Click and drag to create points with curve handles. Double-click or press Return to create the final point.

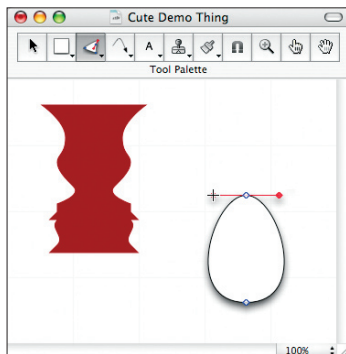

## Line

The Line tool establishes connections between objects. Click the object you wish to connect from, then the object you wish to connect to. You can also create lines that are not connected to anything in particular: double-click an empty spot on the canvas to end the line there.

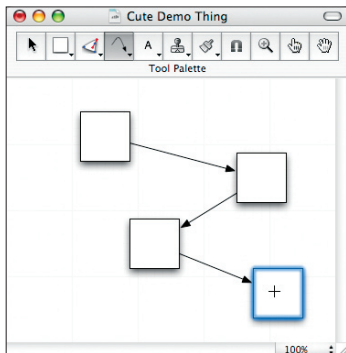

## Text

You can use the Text tool to create text objects, or to edit the text of existing objects. Click an empty spot on the canvas to create a text object that resizes to fit the text inside it. Click any object already on the canvas to edit its text.

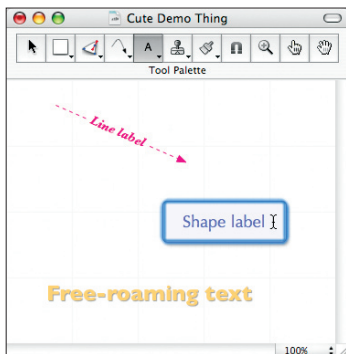

## Rubber Stamp

The Rubber Stamp tool is handy for creating multiple copies of an object. Click an object to “pick it up”, then click anywhere on the canvas to put down a copy of the object. Once you have picked up an object, you can use the tool’s pop-up menu to do the stamp, or just Option-click a different object to pick that one up instead.

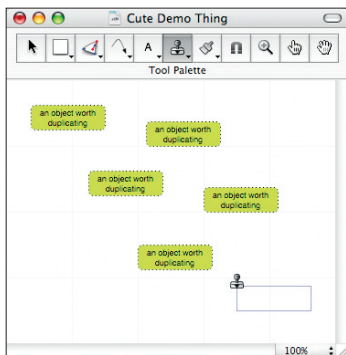

## Style Brush

The Style Brush works a lot like the rubber stamp, but with styles instead of whole objects. Click an object to suck up its styles (stroke, fill, font, and such) into the brush, then click another object to apply those styles to it. You can use the tool’s pop-up menu to choose exactly what kinds of styles to absorb, or to clear the contents of the Style Brush.

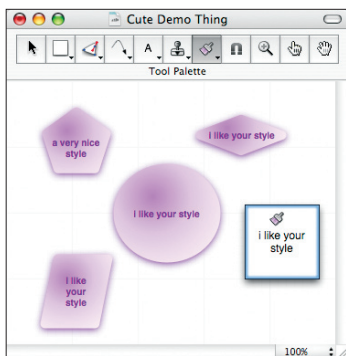

## Magnet

Click an object to stick a new magnet on there, or drag existing magnets around to rearrange them. Option-click magnets to get rid of them.

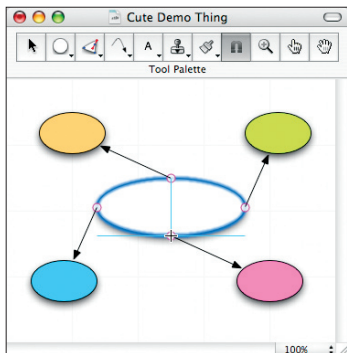

## Zoom

Click somewhere with the Zoom tool to get a closer view of that area of the canvas, or Option-click to zoom out. You can also click and drag to indicate the exact rectangle you'd like to zoom in on.

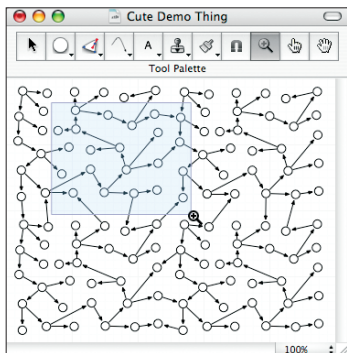

## Browse

The Browse tool is for using interactive OmniGraffle documents. If you click an object that has an action (set with the Action inspector), its action is performed. This can move to another part of the document, open a file, visit a URL, or run an AppleScript.

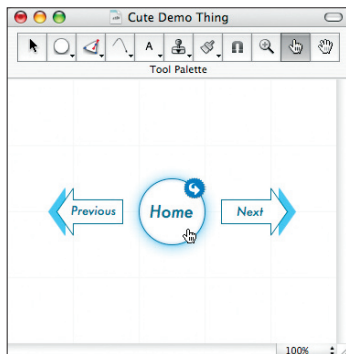

## Hand

The Hand tool is a hand that you can use to drag the canvas around and reveal areas of it that are hidden offscreen.

Don't try dragging the canvas around with your actual hand. It doesn't work. (Trust us.)

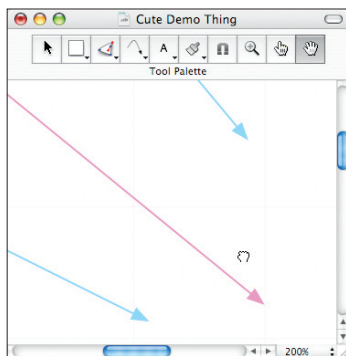

## Utility Drawer

Click the **Canvases** tab (in OmniGraffle Pro) or the **Layers** tab (in OmniGraffle Standard) at the top of the drawer to manage canvases and layers, or click the **Outline** tab to see the outline view.

### Canvases

OmniGraffle Pro can work with documents containing many canvases. Each canvas is self-contained; it keeps track of its size, settings, and contents separately from the other canvases. For instance, you could keep one document for a project you're working on, and have each canvas contain a diagram of a completely different aspect of the project.

Click the triangle next to a canvas to expand its constituent layers. Each layer has buttons to toggle its visibility, printability, and editability. You can select a canvas to work with all of its layers at once, or you can select a single layer to work with it individually. Drag canvases and layers around the list as you see fit, or even between documents. The color well next to a canvas sets its background color.

A master canvas can be applied to a canvas, where it acts like a kind of background layer. Drag a master canvas and drop it on a canvas to apply it. The canvas then depends on the master, and displays the contents of the master behind its own contents. Any subsequent changes to the master are reflected by the canvases that depend on it.

The controls at the bottom of the drawer are for creating, manipulating, and deleting your canvases, layers, and master canvases.

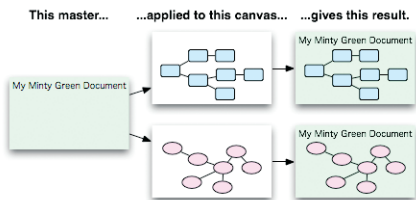

## Outline view

The outline view is a marvelously quick way to build a hierarchy of objects. For each item you type into the outline, a new object appears on the canvas. Press Return to create a new item; press Tab to indent the selected item or Shift-Tab to outdent it. You can also drag items around the outline as you see fit. The diagram automatically updates to reflect every change you make to the outline.

Toward the bottom of the drawer are buttons for creating, deleting, and modifying items in the outline, a diagram style menu, settings for how the diagram should behave while you edit the outline, and a preview of the current diagram style.

### OG4 TIP

#### Diagram styles

When you turn an outline into a diagram, there is an infinite number of different ways you could style the items and lay them out. A diagram style is a special OmniGraffle file that acts as an example for how to graphically represent an essentially text-based outline. You can use one to specify how imported OmniOutliner files should look, or to style the outline you're creating in OmniGraffle's own outline view. Use the pop-up menu at the bottom of the outline view to select a style that works well for your diagram. If you like, you can even lay out a diagram the way you like it, save it as a diagram style, and share it with others.



## Stencils

Rather than creating all of the objects you need one by one, you can pull ready-made objects from a stencil. Several handy stencils come with OmniGraffle, and you can download more from our web site. You can even make your own stencils from whichever objects you like.

Select the stencil you want from the **Stencils** menu, then just drag an object from the stencil to the canvas.

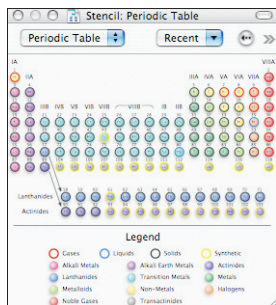
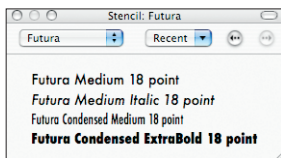
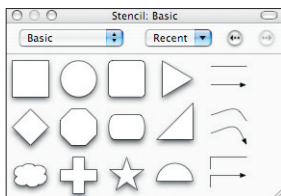

## OG4 TIP

### Possibly The Most Entertaining New Feature

In addition to drawing with the Shape and Pen tools, dragging objects from a stencil, or creating items from the outline view, there is another truly cool way to rapidly make and connect objects. With a shape selected, Command-click an empty spot on the canvas to create a connected object there. Option-Command-click an empty spot to create a sibling object instead of a child. Once you see this in action with the Diagram Layout inspector's "Lay out diagrams after any connection change" option selected, you might never leave your home again.

## Preferences

### General

The Preferences are application-wide settings that are in effect for every document you work on. We've tried to make OmniGraffle work the way you expect, but when it doesn't, try making some adjustments here.

### Tool Palette

Choose which tools you'd like to see and where you'd like to see them. You can also define a "hot key" for each tool; then while you are editing a diagram, hold a hot key to switch to that tool for as long as you are holding the key.

### Templates

You can tell OmniGraffle to use a certain template for each new document you create. For more information about templates, see the page 55 (**Save, print, import, export**).

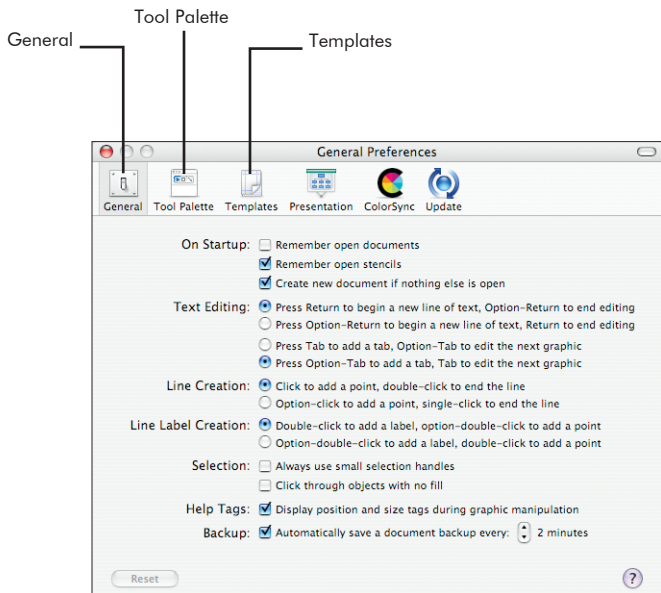

Continued on next page ➤

## Preferences

### Presentation

In here are some options for OmniGraffle's presentation mode. These mainly deal with highlighting objects during a presentation.

### ColorSync

OmniGraffle Pro supports Apple's ColorSync technology, which tries to keep colors as accurate as possible when viewed on any ColorSync-compliant display and when printed on any ColorSync-compliant printer. Use this pane to turn on ColorSync and set up color profiles.

### Update

You can always be sure that your copy of OmniGraffle is up to date because it can automatically check for new versions of itself. Of course, OmniGraffle only checks when you have an active internet connection.

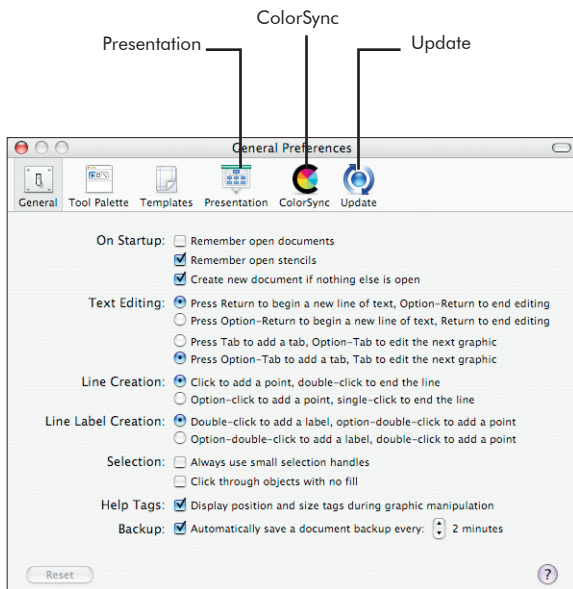

## Save, Print, Import, Export

### Saving

The saving commands in the **File** menu act as you would expect in any application; **Save** writes any changes you've made to the file on the disk, while **Save As** writes your changes to a completely new file.

Select **Save As Template...** to create a file that can be used as a starting point for new documents. The **Save As Diagram Style...** command creates a file to which you can conform imported OmniOutliner files and hierarchies created with OmniGraffle's outline view.

#### OG4 TIP

### Templates

Templates are starting points for new documents. Say you tend to work with a particular paper size, orientation, grid, and canvas setup fairly often. Just create a document that looks the way you want your new documents to look, and save it as a template using the **File ▶ Save As Template...** command. You can then use **File ▶ New From Template** to select a template for your next document. You can also use the Templates preference pane to choose one template to use as the default for all new documents.

### Printing

The way OmniGraffle prints your diagram is largely determined by the Canvas Size inspector. Of course, all of the standard page setup and printing controls are available in the **Page Setup** and **Print** dialog boxes available from the **File** menu.

## Importing from other formats

OmniGraffle can read a bunch of different file formats; just open a supported file normally from the **File** menu to open a copy of it as an OmniGraffle file. You can import diagrams from Visio® XML (in OmniGraffle Pro), DOT, and Diagram 2 files. You can also import outlines from OmniOutliner and apply outline styles to convert them to diagrams. If you are a technically-minded person, you might like to import Project Builder, Interface Builder, EOModeler, and framework files to create visualizations of their contents.



Complicated  
Program.xcode



Very Pleasant Data.vdx



Important-looking  
document.oob



Revolutionary New  
Interface.nib

## Exporting to other formats

To export a diagram is to tell OmniGraffle to do its best at approximating the diagram's contents in some file format other than its own. You could, for instance, export to a Visio® XML file (for your Windows colleagues), a PNG or SVG file (for displaying on the web or e-mailing to friends), or even an OmniOutliner file (for people with excellent taste in idea organization applications). Exporting creates a new file in the selected format, leaving the original OmniGraffle file on your screen just the way it is.



Project Tasks.graffle



Project Tasks.pdf



Project Tasks.tiff



Project Tasks.png



Project Tasks.eps



Project Tasks.jpg



Project Tasks.html



Project Tasks.outline



Project Tasks.svg



Project Tasks.ppt



Project Tasks.psd



Project Tasks.bmp



Project Tasks.vdx

## LinkBack

LinkBack means you can copy content from one application and paste it into another application, without losing any of the content's flexibility.

For example, say you copy some OmniGraffle objects and paste them into another LinkBack-compatible application, where they become embedded in the other application's document. Days later, you could double-click the embedded data to edit it in OmniGraffle. When you save the changes, they are reflected in the other application immediately.

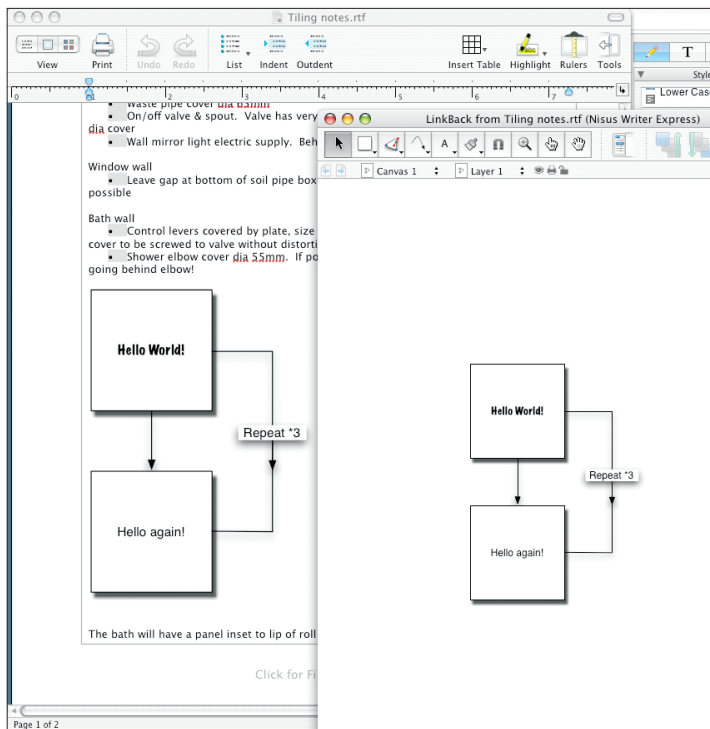



## Onscreen Help

OmniGraffle comes with an extensive onscreen help system, which covers all of the fiddly little details that this manual doesn't. Just select **OmniGraffle Help** from the **Help** menu and you'll find a searchable, browsable cornucopia of OmniGraffle knowledge.

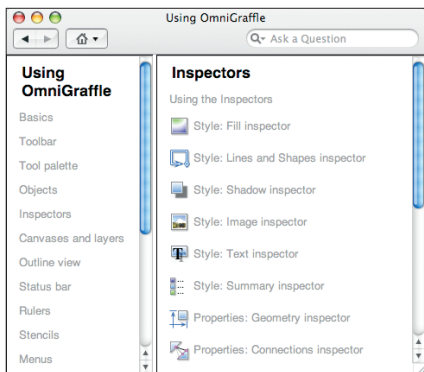



## Walkthroughs

We've prepared some interactive OmniGraffle documents to step you through using the software. If you've got a boxed copy of OmniGraffle, you can find them on the disc that came in the box. Otherwise, you can download them from our web site:

<http://www.omnigroup.com/applications/omnigraffle/extras/>

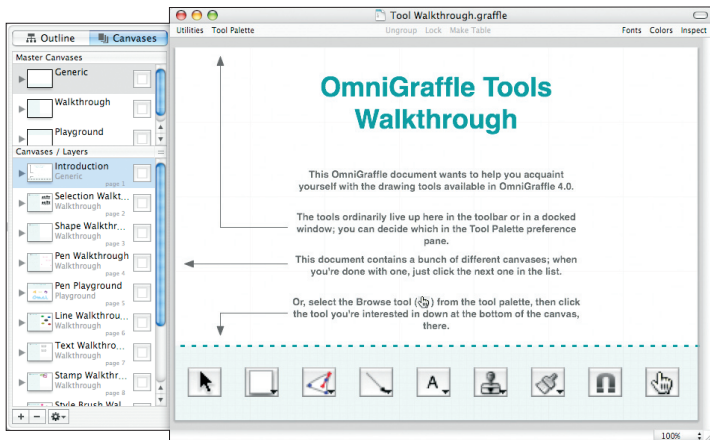

## Further Help

Our web site is a nice first place to look for the latest information about OmniGraffle.

<http://www.omnigroup.com/applications/omnigraffle/>

There's a OmniGraffle users' mailing list, and you're invited! Someone in the community just might be able to help you.

<http://www.omnigroup.com/mailman/listinfo/omnigraffle-users>

If you're really stuck, or if you just want to let us know what you think, go ahead and e-mail us. Select Send Feedback... from the Help menu to conjure up a message addressed to us, or just write to [omnigraffle@omnigroup.com](mailto:omnigraffle@omnigroup.com). We'll do our best to help you out.



